

	2x6 EXTERIOR WALL
	2x6 INTERIOR PLUMBING WALL
	2x4 INTERIOR WALL

WALL LEGEND

FIRST FLOOR

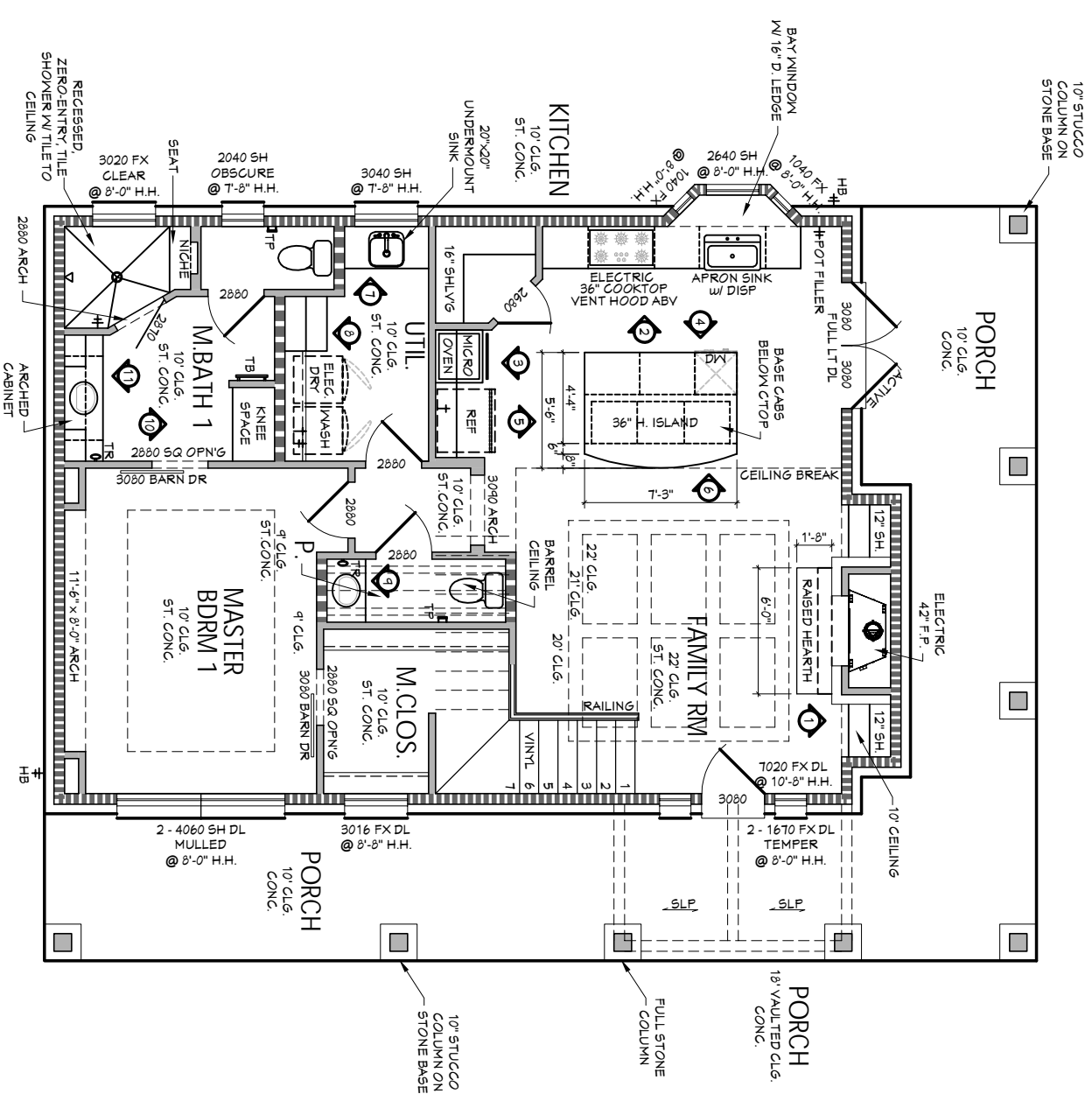

SECOND FLOOR

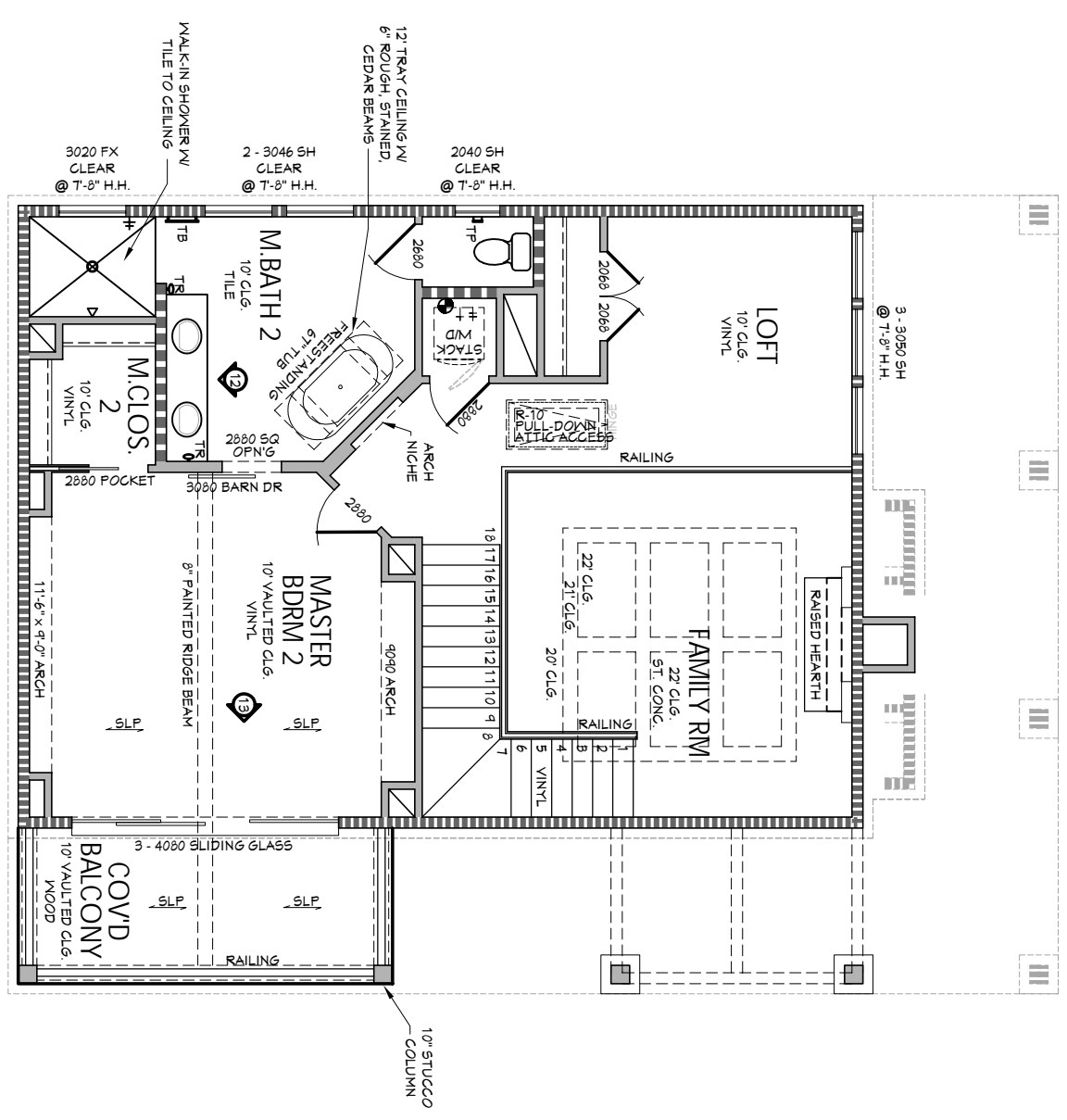

PIRRITANO - Clops Take-Off

DESCRIPTION	CLOP	S.F.
Kitchen	31	S.F.
Kitchen Island	46	S.F.
utility	18	S.F.
master bath 1	26	S.F.
master bath 2	21	S.F.
powder	10	S.F.
family room	12	S.F.

FINAL DRAWINGS
APPROVED PER NOTED CHANGES
HOME OWNER

STAINED CONCRETE

Scale Used:
11x17: 1/8" = 1'-0"
24x36: 1/4" = 1'-0"

<p>TRIM / FINISH PLAN</p> <p>Pirritano Residence</p>	<p>DATE: 8 APR 2022</p> <p>DESIGNER: S.BYRNE</p> <p>PLANNING: N/A</p> <p>SHEET: A-2</p>	<p>KURK★HOMES</p> <p><i>Custom Builders</i></p> <p>12022 Zion Rd. Tomball, Texas 77375 1-800-749-KURK</p>
	<p>DATE: 8 APR 2022</p> <p>DESIGNER: S.BYRNE</p> <p>PLANNING: N/A</p> <p>SHEET: A-2</p>	<p>DATE: 8 APR 2022</p> <p>DESIGNER: S.BYRNE</p> <p>PLANNING: N/A</p> <p>SHEET: A-2</p>

THESE PLANS ARE DRAWN TO COMPLY WITH OWNER'S AND/OR BUILDER'S SPECIFICATIONS AND ANY CHANGES MADE AFTER PRINTING HAS BEEN COMPLETED, WILL BE AT THE OWNER'S AND/OR BUILDER'S EXPENSE AND RESPONSIBILITY. THE BUILDER AND/OR CONTRACTOR SHALL VERIFY ALL DIMENSIONS AND ENCLOSED DRAWINGS PRIOR TO/DURING CONSTRUCTION AND ASSUMES ALL RESPONSIBILITY THEREAFTER. WHILE EFFORTS HAVE BEEN MADE DURING THE PREPARATION OF THESE CONSTRUCTION DOCUMENTS TO AVOID ANY ERRORS AND/OR MISTAKES, THE DESIGN TEAM CAN NOT GUARANTEE AGAINST ERROR.

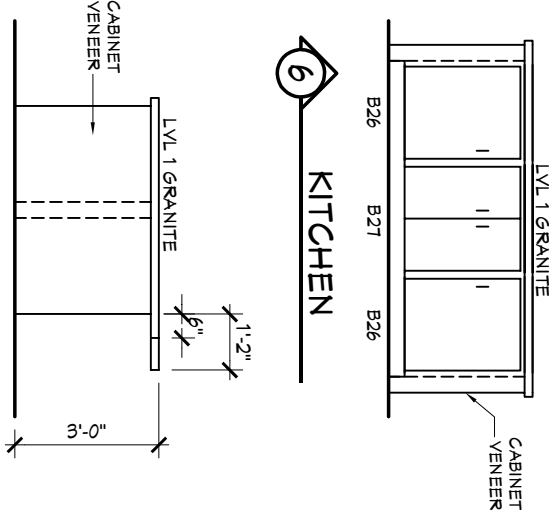
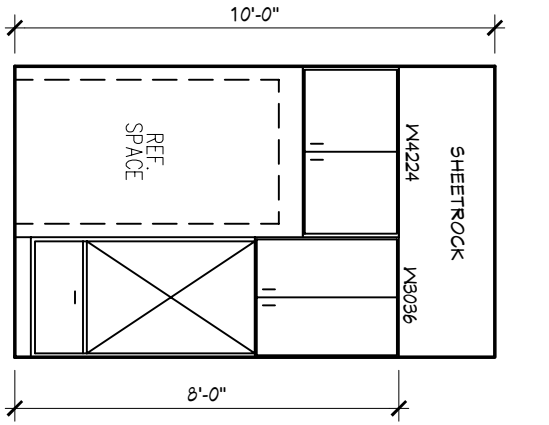
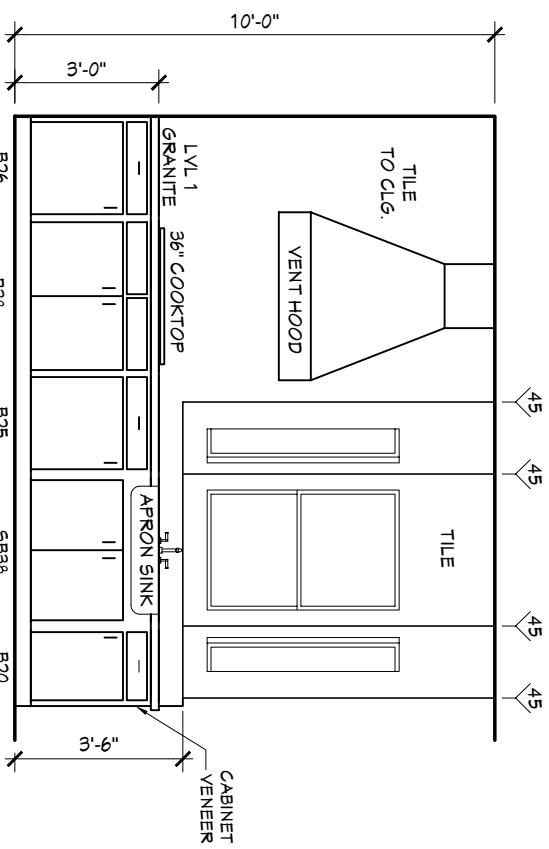

2 KITCHEN

3 KITCHEN

5 KITCHEN

6 KITCHEN

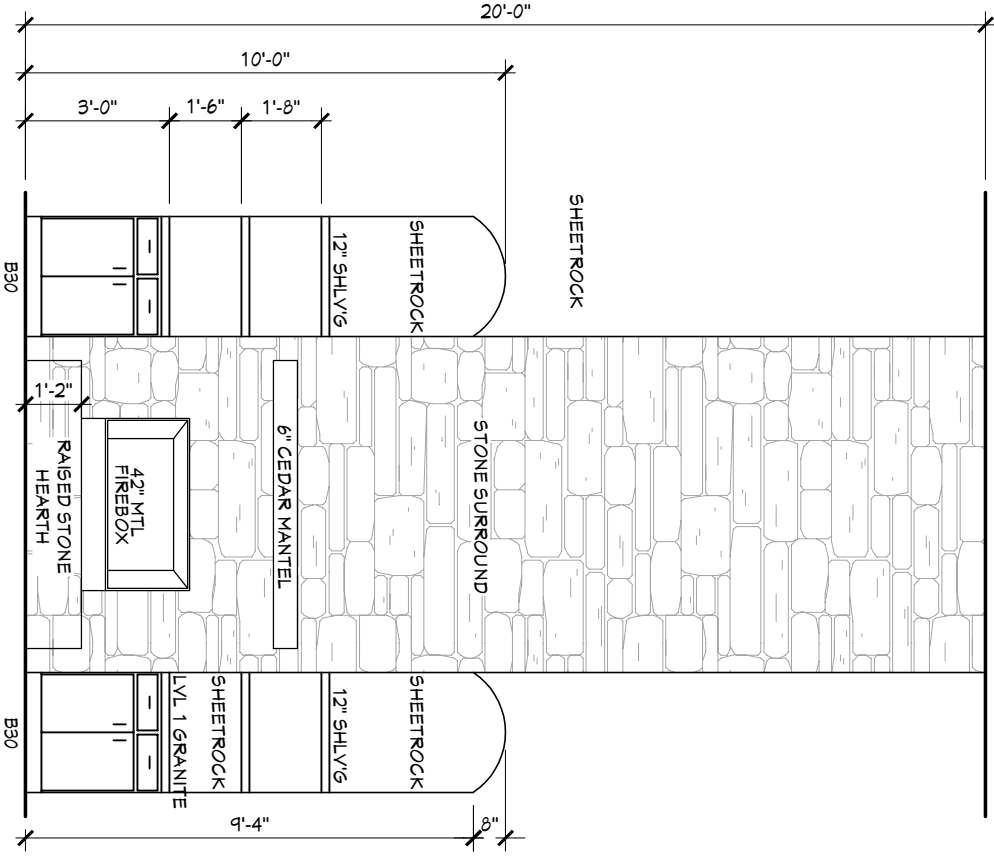

1 FAMILY ROOM

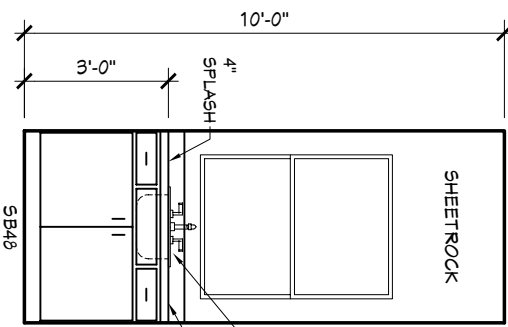

7 UTILITY

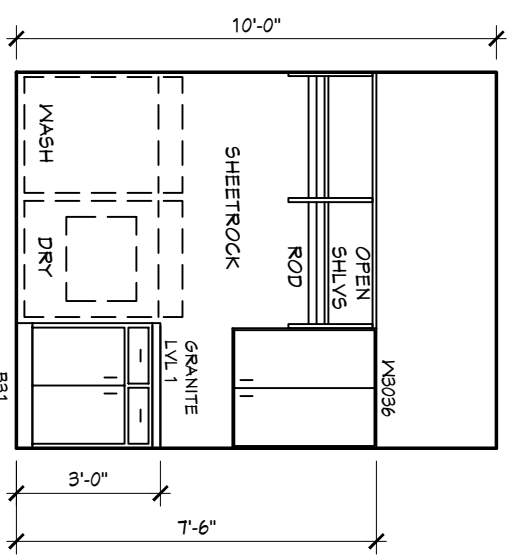

8 UTILITY

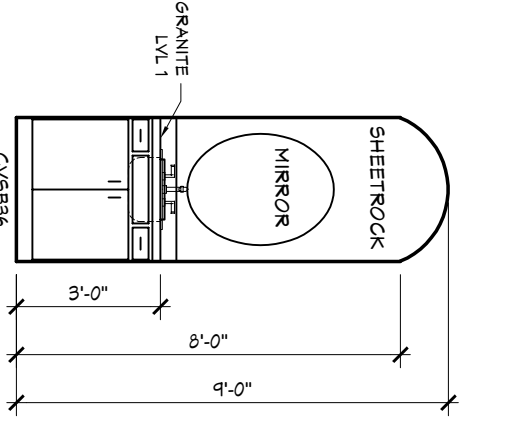

9 POWDER

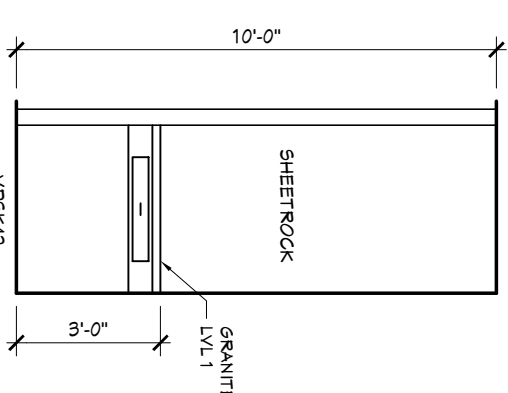

10 M. BATH 1

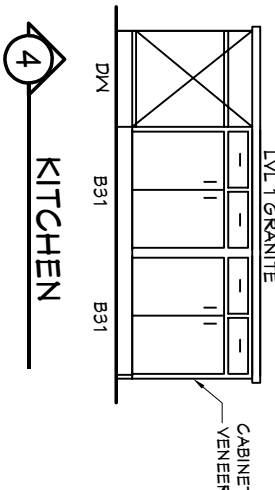

4 KITCHEN

ALL CABINETS PROVIDED USING CABINET ALLOWANCES IN SUPPLEMENTAL

CABINET HARDWARE IS AN OPTION. HARDWARE SHOWN FOR PURPOSE OF DRAWER PULL AND DOOR SWING

FINAL DRAWINGS
APPROVED PER NOTED CHANGES
HOME OWNER

STAINED CONCRETE

Scale Used:
11x17: 1/4" = 1'-0"
INTERIOR ELEVATIONS 24x36: 1/2" = 1'-0"

<p>12022 Zion Rd. Tomball, Texas 77375 1-800-749-KURK</p>		<p>INTERIOR ELEVATIONS Pirritano Residence</p>		<p>DATE: 8 APR 2022 DESIGNER: S. BYRNE PLAN NO.: N/A SHEET: A-3</p>
---	--	---	--	---

THESE PLANS ARE DRAWN TO COMPLY WITH OWNER'S AND/OR BUILDER'S SPECIFICATIONS AND ANY CHANGES MADE AFTER PRINTING HAS BEEN COMPLETED, WILL BE AT THE OWNER'S AND/OR BUILDER'S EXPENSE AND RESPONSIBILITY. THE BUILDER AND/OR CONTRACTOR SHALL VERIFY ALL DIMENSIONS AND ENCLOSED DRAWINGS PRIOR TO/DURING CONSTRUCTION AND ASSUMES ALL RESPONSIBILITY THEREAFTER. WHILE EFFORTS HAVE BEEN MADE DURING THE PREPARATION OF THESE CONSTRUCTION DOCUMENTS TO AVOID ANY ERRORS AND/OR MISTAKES, THE DESIGN TEAM CAN NOT GUARANTEE AGAINST ERROR.

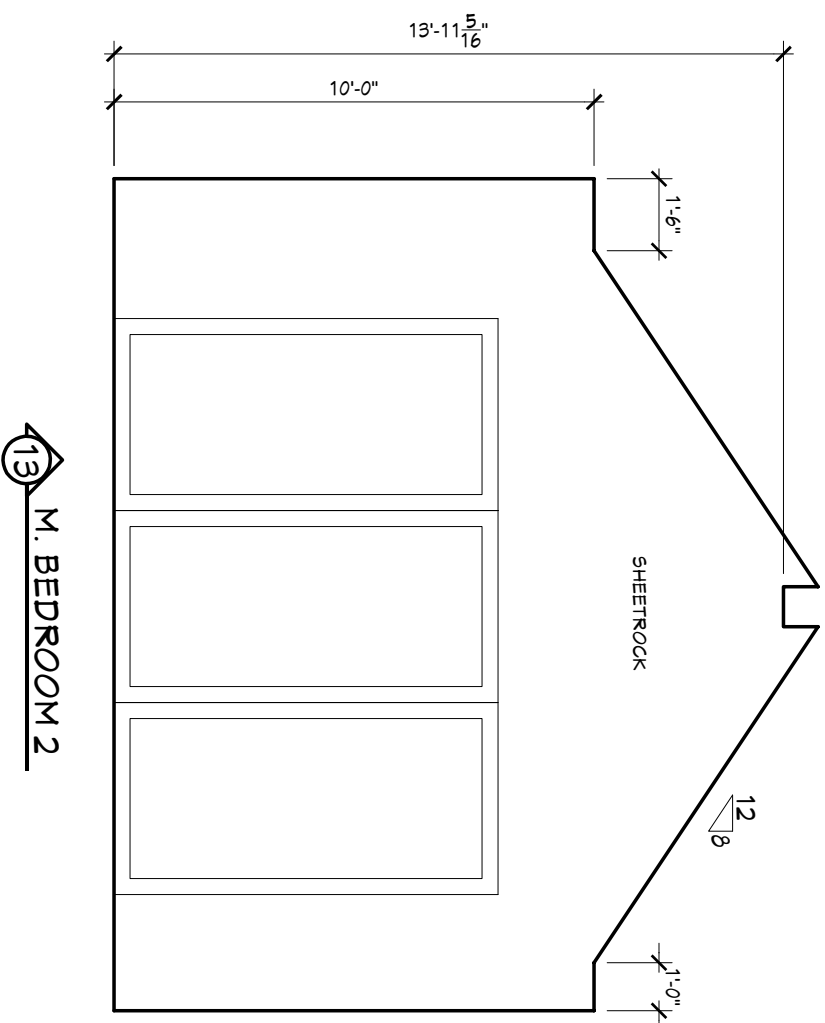
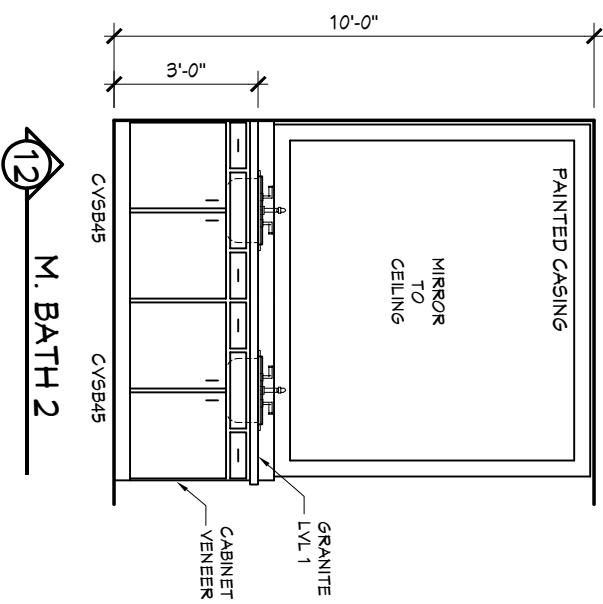
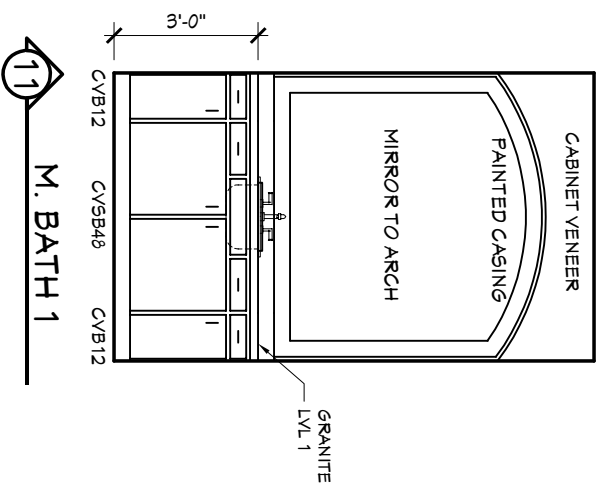

STAINED CONCRETE

FINAL DRAWINGS
 APPROVED PER NOTED CHANGES
 HOME OWNER

Scale Used:
 11x17: 1/4" = 1'-0"
 24x36: 1/2" = 1'-0"

SHEET A-4	DATE: 8 APR 2022	INTERIOR ELEVATIONS Pirritano Residence	KURK★HOMES <i>Custom Builders</i> 12022 Zion Rd. Tomball, Texas 77375 1-800-749-KURK
	DESIGNER: S. BYRNE		
PLAN NO. N/A	DATE: 8 APR 2022	FINAL	

THESE PLANS ARE DRAWN TO COMPLY WITH OWNER'S AND/OR BUILDER'S SPECIFICATIONS AND ANY CHANGES MADE AFTER PRINTING HAS BEEN COMPLETED, WILL BE AT THE OWNER'S AND/OR BUILDER'S EXPENSE AND RESPONSIBILITY. THE BUILDER AND/OR CONTRACTOR SHALL VERIFY ALL DIMENSIONS AND ENCLOSED DRAWINGS PRIOR TO/DURING CONSTRUCTION AND ASSUMES ALL RESPONSIBILITY THEREAFTER. WHILE EFFORTS HAVE BEEN MADE DURING THE PREPARATION OF THESE CONSTRUCTION DOCUMENTS TO AVOID ANY ERRORS AND/OR MISTAKES, THE DESIGN TEAM CAN NOT GUARANTEE AGAINST ERROR.

ELECTRICAL LEGEND

⊕	SWITCH
⊕ 3	3-POLE SWITCH
⊕ 4	4-POLE SWITCH
○	WALL MOUNTED LIGHT FIXTURE
○	CEILING MOUNTED LIGHT FIXTURE
⊗	SMOKE & CARBON MONOXIDE DETECTOR
⊗ S.D.	SMOKE DETECTOR
⊗ S.D.	MINI RECESS CAN
⊗	RECESS CAN
⊗	DIRECTIONAL CAN (EB)
⊗	CHIMES
⊗	CAT5 DATA LINE
⊗	TELEPHONE JACK
⊗	TELEVISION JACK
⊗	DOOR BELL
⊗	GAS
⊗	EXHAUST FAN
⊗	HOSE BIB / WATERLINE
⊗	CEILING FAN WITH LIGHT KIT
⊗	CEILING FAN
⊗	120V RECEPT FLOOR PLUG
⊗	120V RECEPTACLE
⊗	220V RECEPTACLE
⊗	GROUND FAULT INTERRUPTOR
⊗	WEATHER PROOF W/ GROUND FAULT INTERRUPTOR
⊗	SWITCH TOP POLE ONLY
⊗	THERMOSTAT
⊗	FLUORESCENT LIGHT PANEL
⊗	UNDERCABINET HALOGEN STRIP, 1-BULB
⊗	EXTERIOR FLOOD LIGHT

BUILDER NOTE:
 (6) TV OUTLETS AND/OR PHONE OUTLETS WILL BE PROVIDED PER BUILDERS SPECIFICATIONS AND WILL BE LOCATED DURING FRAME STAGE PER OWNER/ BUILDER.

ALL SMOKE DETECTORS SHALL BE HARD-WIRED, INTERCONNECTED AND HAVE A BATTERY BACK-UP PER LOCAL CODES

FIRST FLOOR

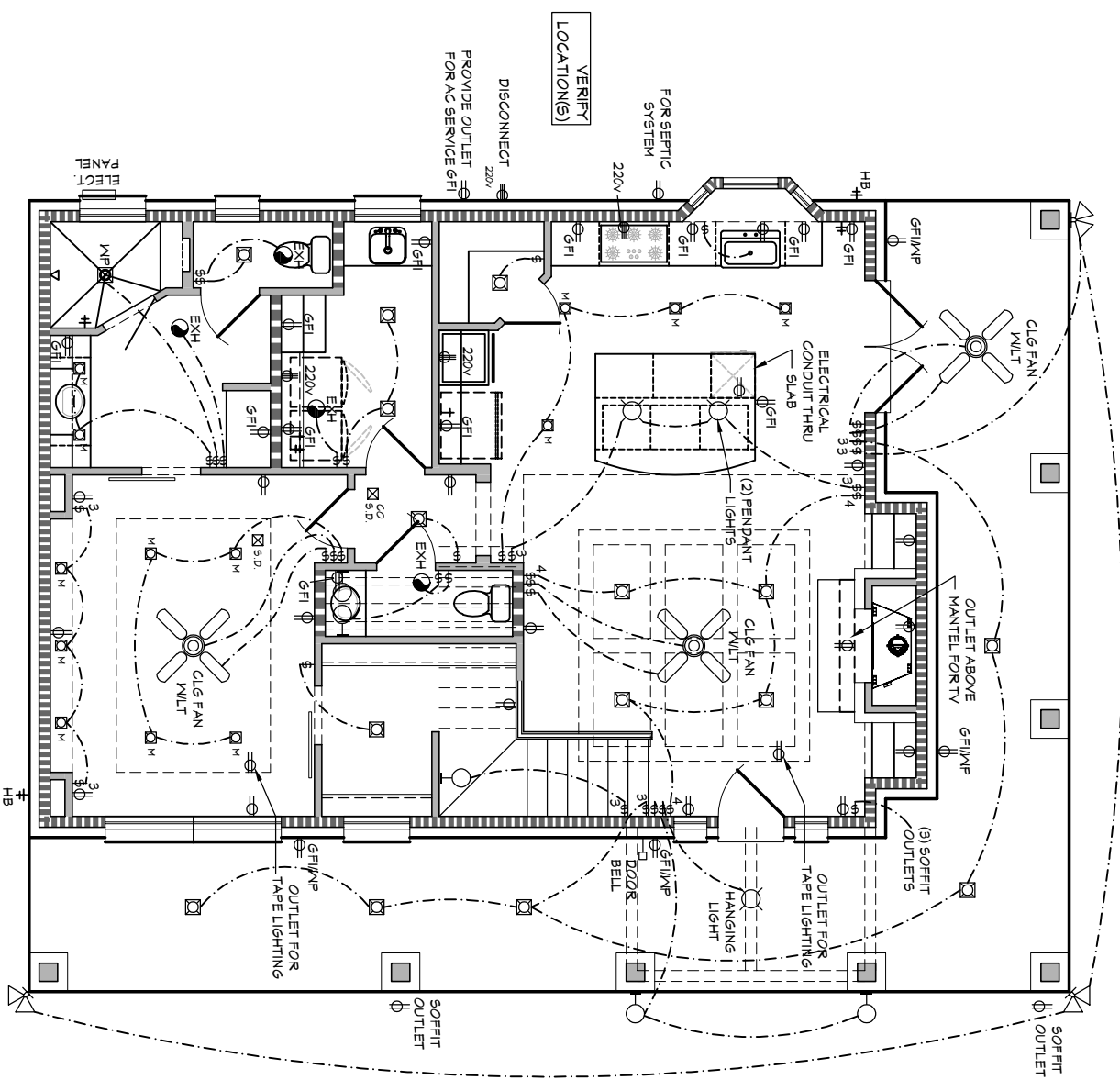

SECOND FLOOR

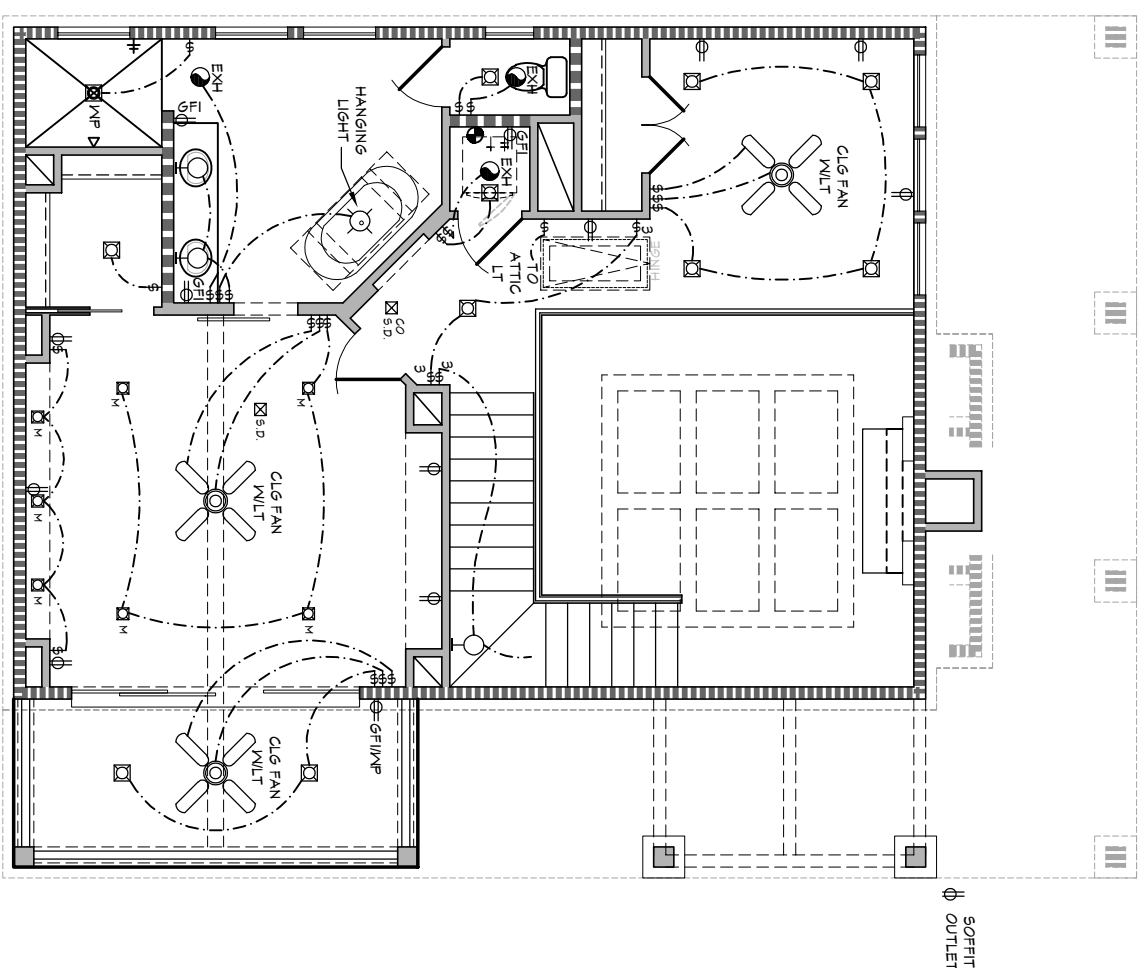

FINAL DRAWINGS
 APPROVED PER NOTED CHANGES
 HOME OWNER

STAINED CONCRETE

GAS WATER HEATERS, DRYER, RANGE AND/OR COOKTOP, FURNACES ARE STANDARD, ALL ELECTRIC APPLIANCES ARE AN OPTION.

ALL LIGHTING AND/OR FANS PROVIDED WITH HOMEOWNERS LIGHTING ALLOWANCE WITH EXCEPTION OF STANDARD RECESSED LIGHTS IN KITCHEN AND SMOKE DETECTORS

Scale Used:
 11x17: 1/8" = 1'-0"
 24x36: 1/4" = 1'-0"

ELECTRICAL PLANS		Pirritano Residence	KURK★HOMES <i>Custom Builders</i> 12022 Zion Rd. Tomball, Texas 77375 1-800-749-KURK
DATE: 8 APR 2022	DESIGNER: S.BYRNE		
PLANNING: N/A	SHEET A-5		

THESE PLANS ARE DRAWN TO COMPLY WITH OWNER'S AND/OR BUILDER'S SPECIFICATIONS AND ANY CHANGES MADE AFTER PRINTING HAS BEEN COMPLETED, WILL BE AT THE OWNER'S AND/OR BUILDER'S EXPENSE AND RESPONSIBILITY. THE BUILDER AND/OR CONTRACTOR SHALL VERIFY ALL DIMENSIONS AND ENCLOSED DRAWINGS PRIOR TO/DURING CONSTRUCTION AND ASSUMES ALL RESPONSIBILITY THEREAFTER. WHILE EFFORTS HAVE BEEN MADE DURING THE PREPARATION OF THESE CONSTRUCTION DOCUMENTS TO AVOID ANY ERRORS AND/OR MISTAKES, THE DESIGN TEAM CAN NOT GUARANTEE AGAINST ERROR.

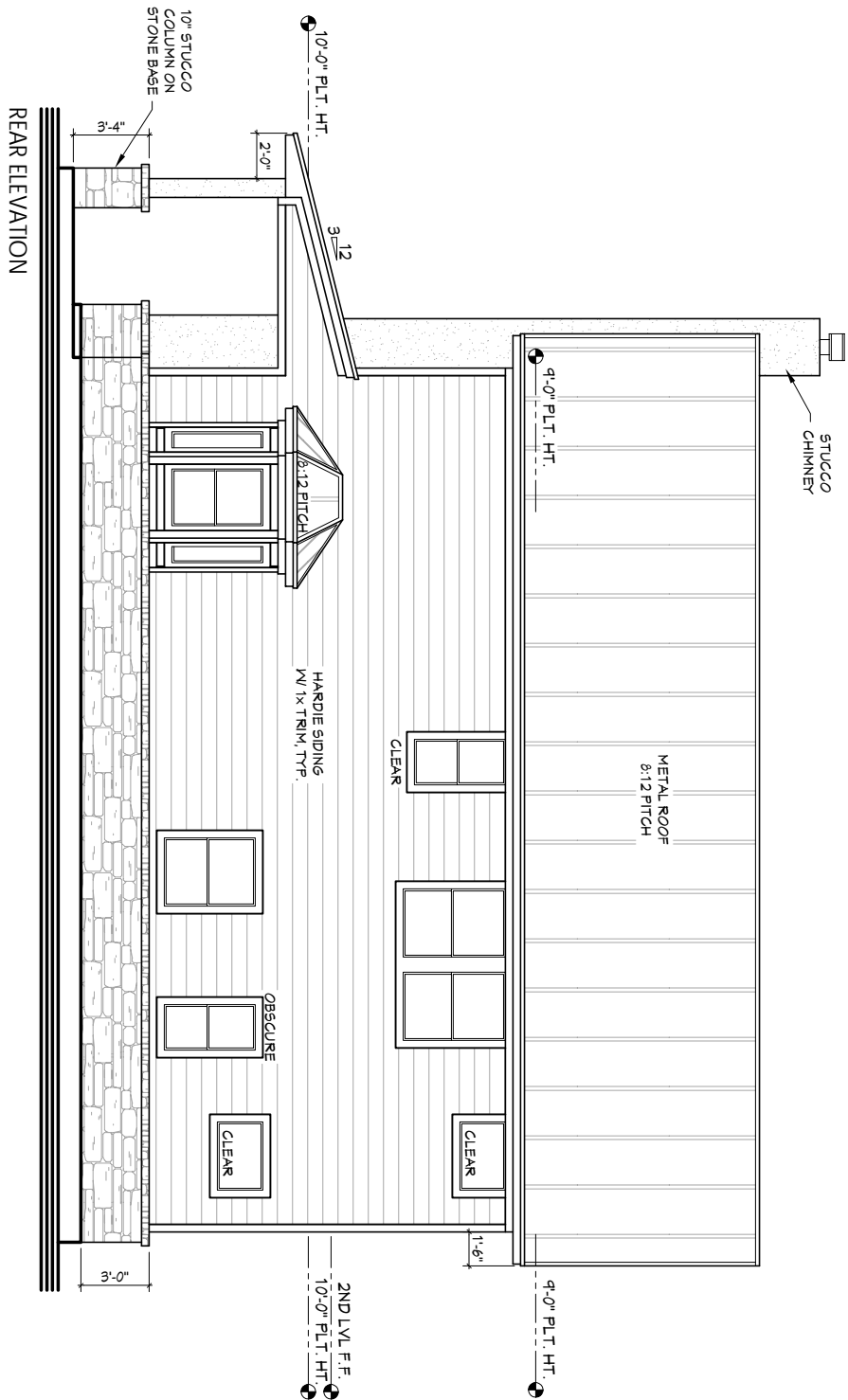
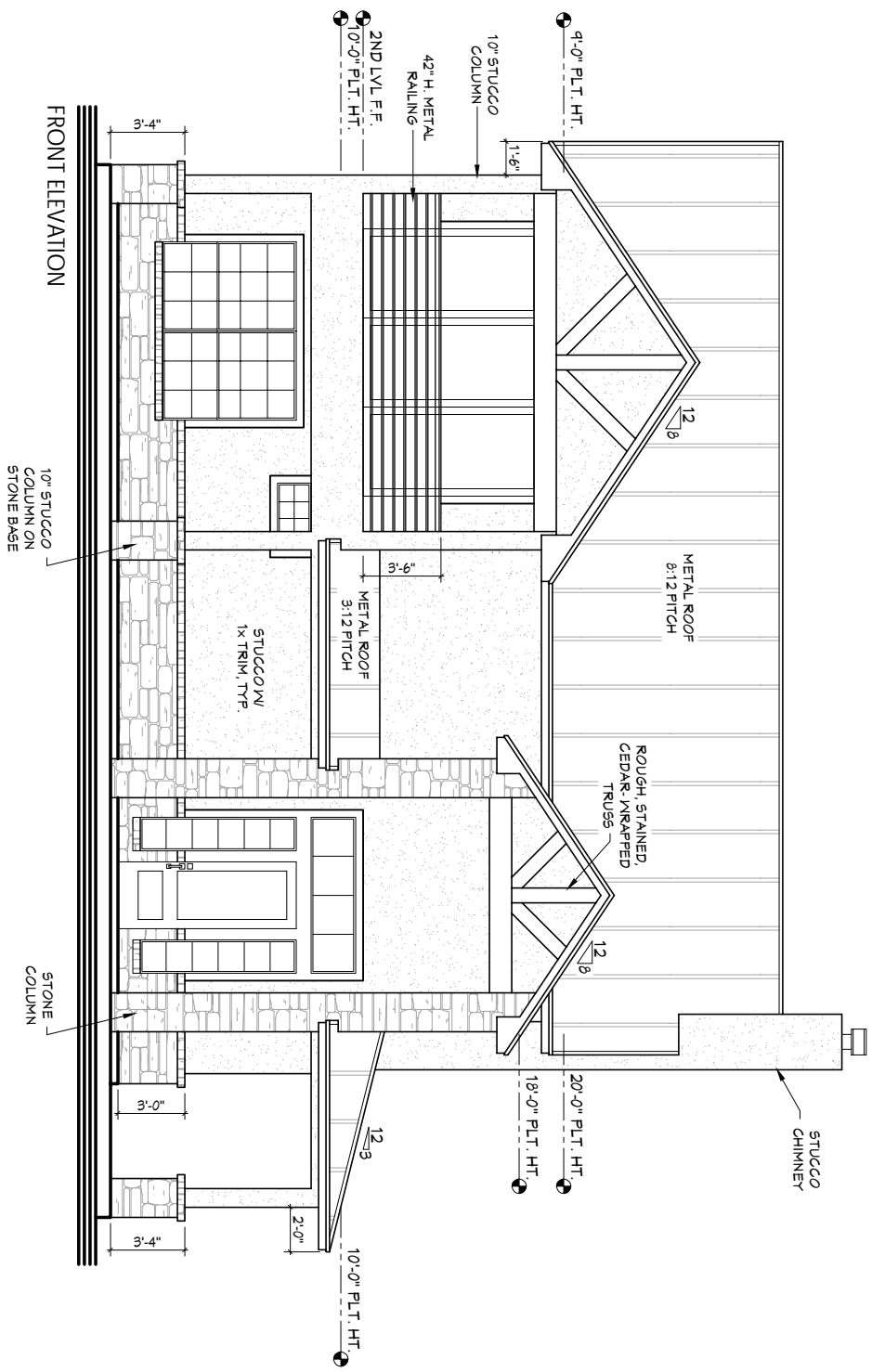

EXTERIOR MATERIAL

stone =	785 s.f.
siding =	730 s.f.
stucco =	2390 s.f.

NOTE CHIMNEY TO BE 2'-0" ABOVE NEAREST STRUCTURE WITHIN 10'-0"

STAINED CONCRETE

Scale Used:
 1/4" = 1'-0"
 1/8" = 1'-0"
 1/16" = 1'-0"

SHEET A-6	PLANNING N/A	DESIGNER S. BYRNE	DATE 8 APR 2022	DATE 8 APR 2022	EXTERIOR ELEVATIONS FRONT / REAR Pirritano Residence	KURK★HOMES <i>Custom Builders</i> 12022 Zion Rd. Tomball, Texas 77375 1-800-749-KURK

THESE PLANS ARE DRAWN TO COMPLY WITH OWNER'S AND/OR BUILDER'S SPECIFICATIONS AND ANY CHANGES MADE AFTER PRINTING HAS BEEN COMPLETED, WILL BE AT THE OWNER'S AND/OR BUILDER'S EXPENSE AND RESPONSIBILITY. THE BUILDER AND/OR CONTRACTOR SHALL VERIFY ALL DIMENSIONS AND ENCLOSED DRAWINGS PRIOR TO/DURING CONSTRUCTION AND ASSUMES ALL RESPONSIBILITY THEREAFTER. WHILE EFFORTS HAVE BEEN MADE DURING THE PREPARATION OF THESE CONSTRUCTION DOCUMENTS TO AVOID ANY ERRORS AND/OR MISTAKES, THE DESIGN TEAM CAN NOT GUARANTEE AGAINST ERROR.

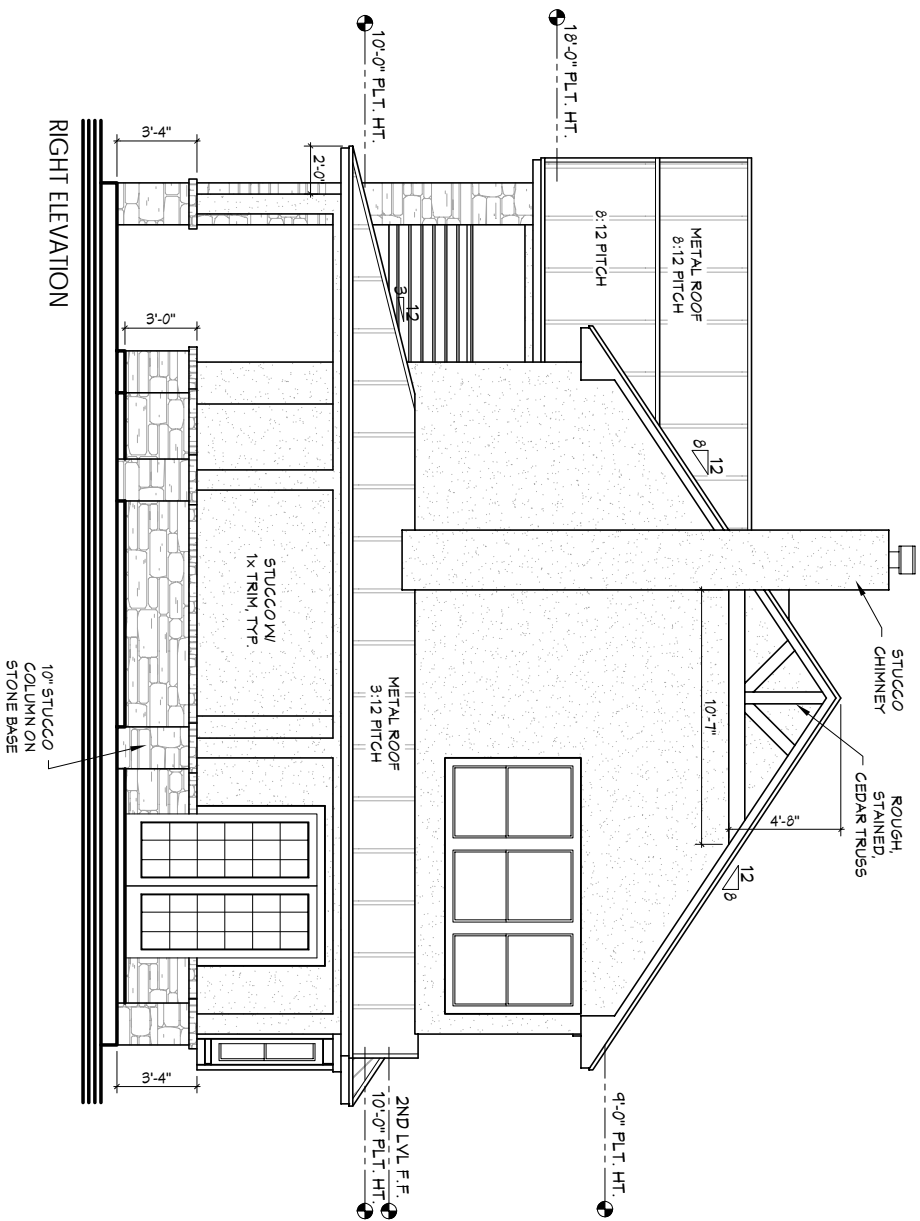
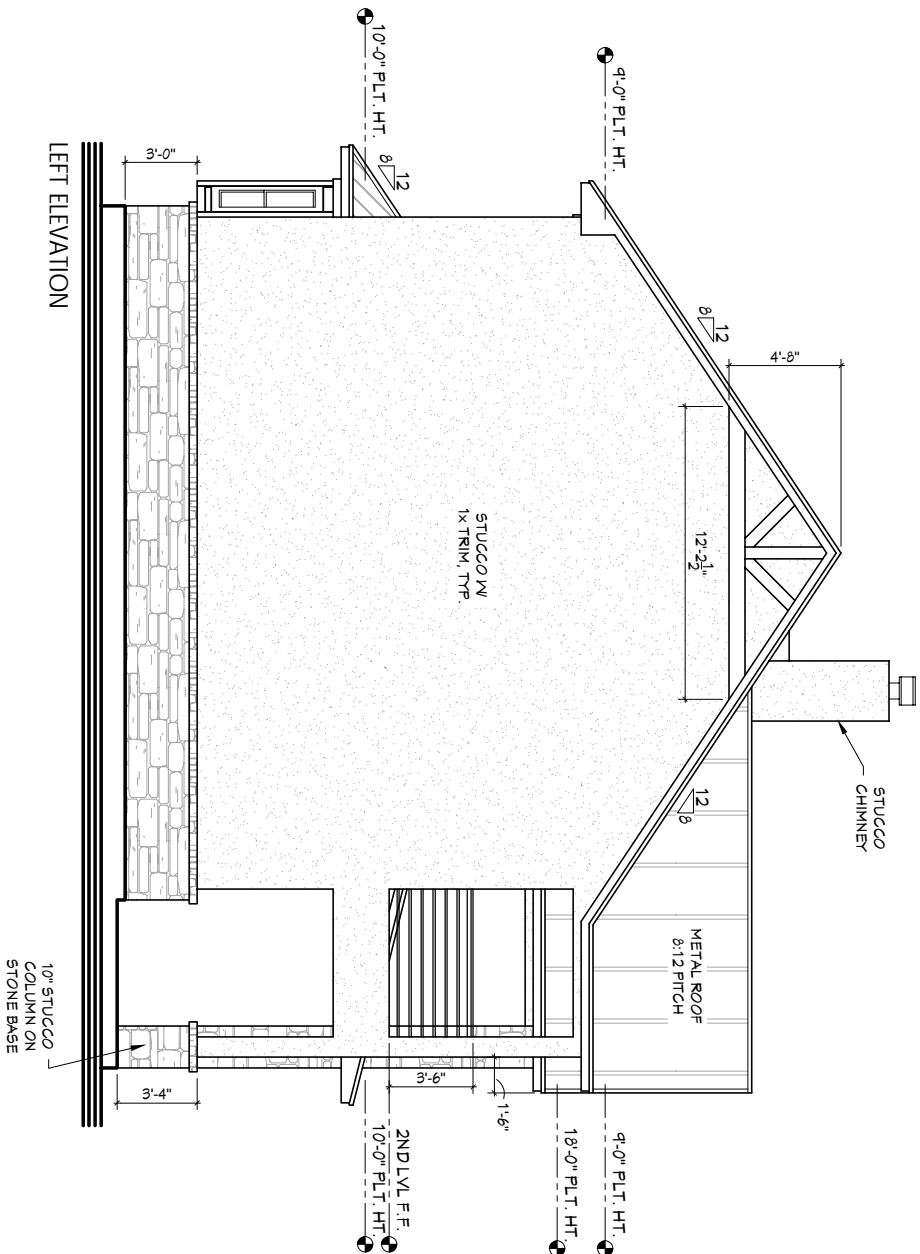

NOTE CHIMNEY TO BE 2'-0" ABOVE NEAREST STRUCTURE WITHIN 10'-0"

STAINED CONCRETE

Scale Used:
 1/4" = 1'-0"
 1/8" = 1'-0"
 1/16" = 1'-0"

SHEET A-7	PLANNING N/A	DESIGNER S. BYRNE	DATE 8 APR 2022	EXTERIOR ELEVATIONS LEFT / RIGHT Pirritano Residence	 12022 Zion Rd. Tomball, Texas 77375 1-800-749-KURK

THESE PLANS ARE DRAWN TO COMPLY WITH OWNER'S AND/OR BUILDER'S SPECIFICATIONS AND ANY CHANGES MADE AFTER PRINTING HAS BEEN COMPLETED, WILL BE AT THE OWNER'S AND/OR BUILDER'S EXPENSE AND RESPONSIBILITY. THE BUILDER AND/OR CONTRACTOR SHALL VERIFY ALL DIMENSIONS AND ENCLOSED DRAWINGS PRIOR TO/DURING CONSTRUCTION AND ASSUMES ALL RESPONSIBILITY THEREAFTER. WHILE EFFORTS HAVE BEEN MADE DURING THE PREPARATION OF THESE CONSTRUCTION DOCUMENTS TO AVOID ANY ERRORS AND/OR MISTAKES, THE DESIGN TEAM CAN NOT GUARANTEE AGAINST ERROR.

STAINED CONCRETE

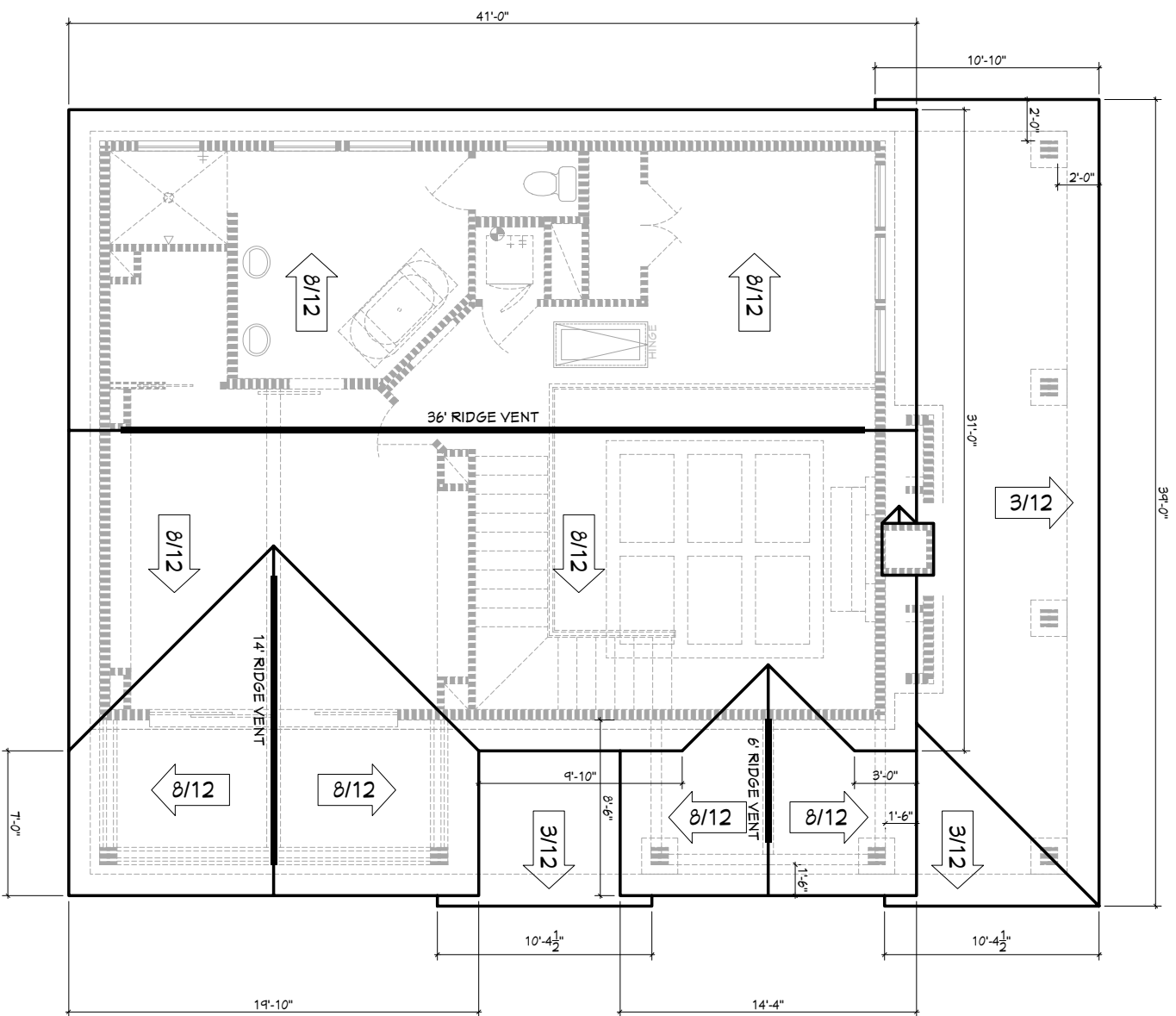

Scale Used:
 11x17: 1/8" = 1'-0"
 24x36: 1/4" = 1'-0"

SHEET A-8	PLANNING N/A	DESIGNER S.BYRNE	DATE 8 APR 2022	DATE 8 APR 2022	FINAL	ROOF PLAN	KURK★HOMES <i>Custom Builders</i> 12022 Zion Rd. Tomball, Texas 77375 1-800-749-KURK
						Pirritano Residence	

THESE PLANS ARE DRAWN TO COMPLY WITH OWNER'S AND/OR BUILDER'S SPECIFICATIONS AND ANY CHANGES MADE AFTER PRINTING HAS BEEN COMPLETED, WILL BE AT THE OWNER'S AND/OR BUILDER'S EXPENSE AND RESPONSIBILITY. THE BUILDER AND/OR CONTRACTOR SHALL VERIFY ALL DIMENSIONS AND ENCLOSED DRAWINGS PRIOR TO/DURING CONSTRUCTION AND ASSUMES ALL RESPONSIBILITY THEREAFTER. WHILE EFFORTS HAVE BEEN MADE DURING THE PREPARATION OF THESE CONSTRUCTION DOCUMENTS TO AVOID ANY ERRORS AND/OR MISTAKES, THE DESIGN TEAM CAN NOT GUARANTEE AGAINST ERROR.

FINAL DRAWINGS
 APPROVED PER NOTED CHANGES
 HOME OWNER

STAINED CONCRETE

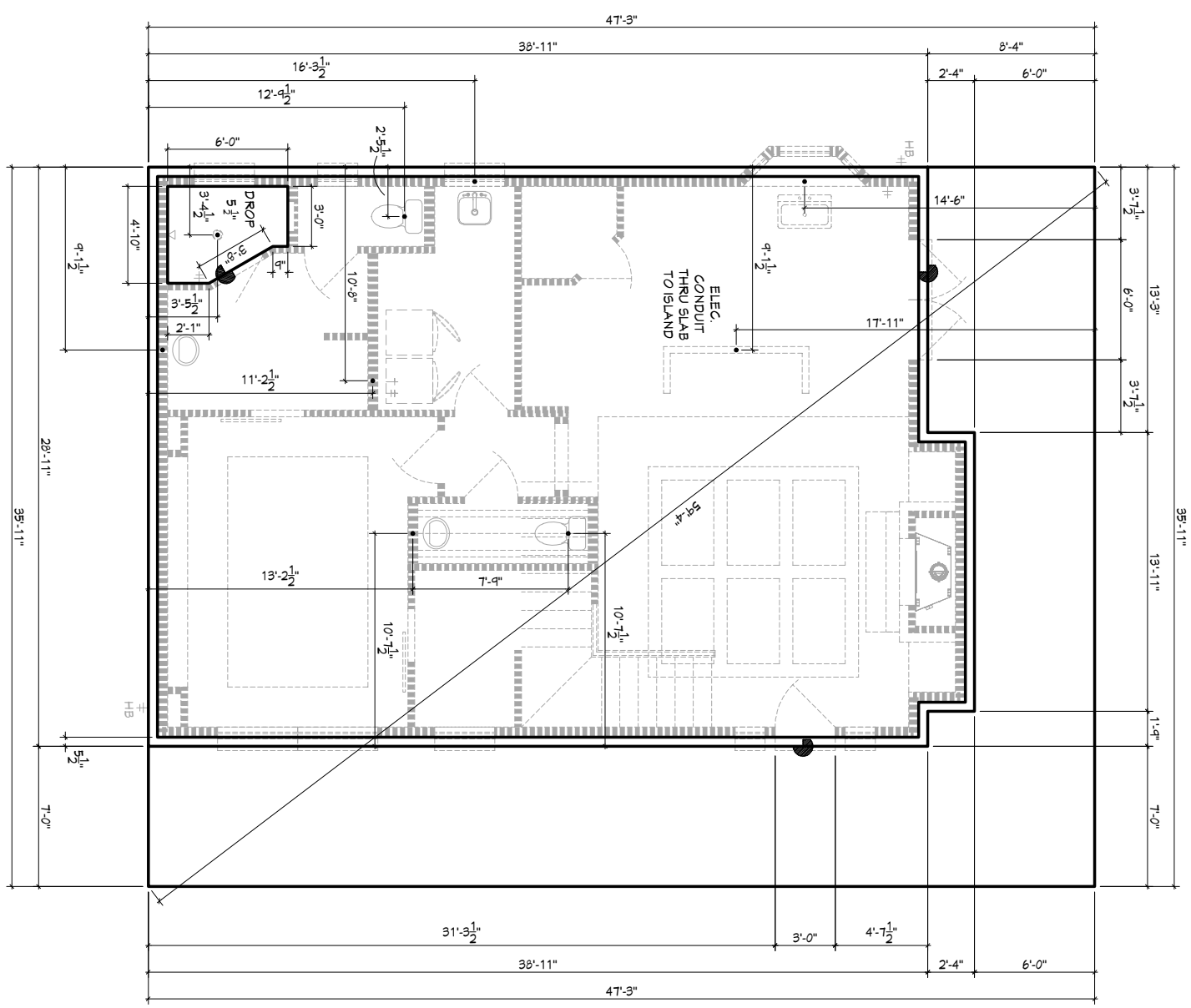

Scale Used:
 11x17: 1/8" = 1'-0"
 24x36: 1/4" = 1'-0"

SHEET A-9	PLANNING N/A	DESIGNER S. BYRNE	DATE 8 APR 2022	DATE 8 APR 2022	ROUGH PLUMBING / FORM LAYOUT Pirritano Residence	KURK★HOMES <i>Custom Builders</i> 12022 Zion Rd. Tomball, Texas 77375 1-800-749-KURK

THESE PLANS ARE DRAWN TO COMPLY WITH OWNER'S AND/OR BUILDER'S SPECIFICATIONS AND ANY CHANGES MADE AFTER PRINTING HAS BEEN COMPLETED, WILL BE AT THE OWNER'S AND/OR BUILDER'S EXPENSE AND RESPONSIBILITY. THE BUILDER AND/OR CONTRACTOR SHALL VERIFY ALL DIMENSIONS AND ENCLOSED DRAWINGS PRIOR TO/DURING CONSTRUCTION AND ASSUMES ALL RESPONSIBILITY THEREAFTER. WHILE EFFORTS HAVE BEEN MADE DURING THE PREPARATION OF THESE CONSTRUCTION DOCUMENTS TO AVOID ANY ERRORS AND/OR MISTAKES, THE DESIGN TEAM CAN NOT GUARANTEE AGAINST ERROR.